

Multi/Single Band 300mm & 370mm Profile Panel Antenna Installation and Operation Instructions Including APM-F-042-GL-E, APM-T-080-GL-E APM-T-045-GL-E, APM-T-041-GL-E & APM-T-029-GL-E Mounting Kits



General

This instruction sheet contains all necessary information required to assist in the correct installation of RFS Single and Multiband Band 300mm and 370mm Profile Panel Antennas. These antennas can be supplied with either manually adjustable electrical downtilt or AISG-compatible remotely controlled electrical downtilt. Mechanical downtilt is also available if required, depending on the type of mounting kit selected.

The following symbols can be found next to text outlining important information.



Please follow the procedure marked with this symbol precisely. Non-compliance may lead to damage of the product.



Handy tips when installing product.

Unpacking

Make sure that the antenna and the accessory items listed below are provided and have not been damaged during transport.

- Antenna
- Mounting kit (mounting kit components are given on mounting assembly drawing supplied).
- Hex Key 6mm AF (supplied with adjustable downtilt antennas only).

Mounting Kits	0 – 800mm Antennas	800 – 1100mm Antennas	1100 – 1500mm Antennas	1500 – 2700mm Antennas
Fixed Downtilt	APM-F-042-GL-E	APM-F-042-GL-E	APM-F-042-GL-E	APM-F-042-GL-E
Mechanical Downtilt	APM-T-080-GL-E	APM-T-045-GL-E	APM-T-041-GL-E	APM-T-029-GL-E

Table 1: Mounting Kits Part Numbers for different Antennas

Installation Instructions



Ensure a torque spanner is used when tightening fasteners, see the mounting kit diagrams on the following pages for the correct torque recommendations.

Installation Instructions - Fixed Downtilt Mounting Kit for 800 – 2700mm Antennas
- (APM-F-042-GL-E)

Assemble both mounting kits as per Figures 8 of this document



1. Attach the mounting kit assembly to the antenna, before trying to clamp the brackets to the pole.

Figure 7: Correctly Assembled Mounting Bracket for Fixed Downtilt Antenna

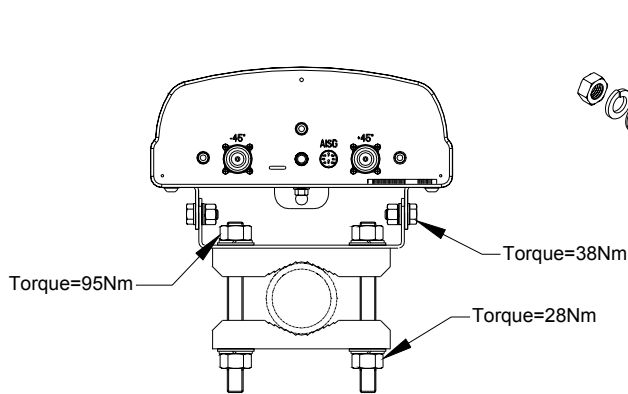

Figure 8. Fixed Downtilt Mounting Bracket Assembled to Antenna

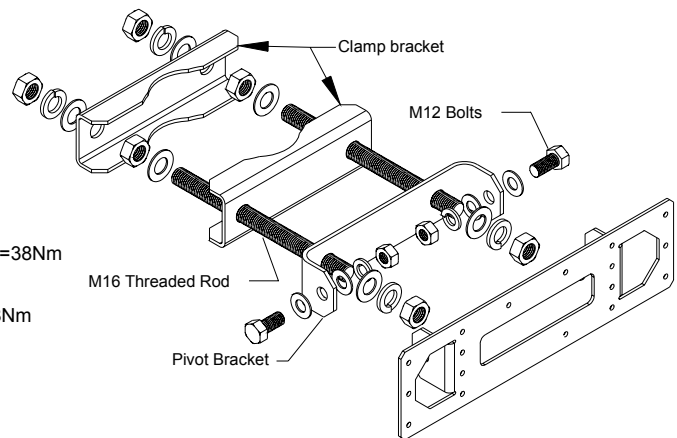

Figure 9. Fixed Downtilt Mounting Bracket Exploded Assembly

Installation Instructions – Mechanically Adjustable Downtilt Mounting Kit for 0-800mm Antennas - (APM-T-080-GL-E)

Assemble both mounting kits as per Figures 4 and 5 of this document.



1. Attach the upper and lower mounting kit assemblies to the antenna, before trying to clamp the brackets to the pole.
2. Downtilt angles of 0°, 5°, 10° and 15° may be obtained with the correct adjustment of the tilt arm bracket.
 - For 0° downtilt the tilt arm may be stowed as show in Figure 6.
 - 5°-15° downtilt can be achieved by aligning the corresponding hole in the tilt arm to the pivot bracket which mates against the mounting pole, as shown in Figure 5. The first hole is for 5° downtilt, with each consecutive hole resulting in an increased inclination of 5°.

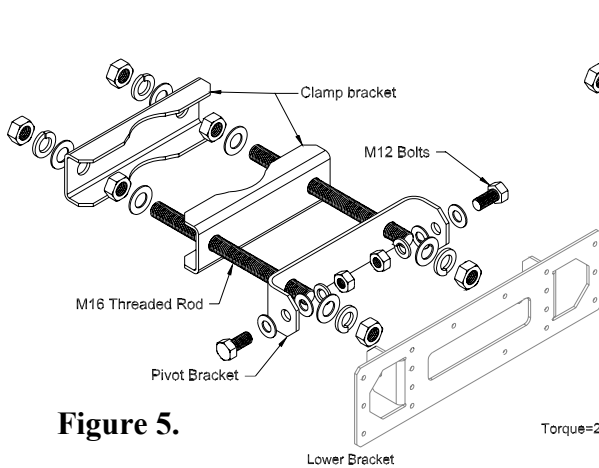

Figure 5.

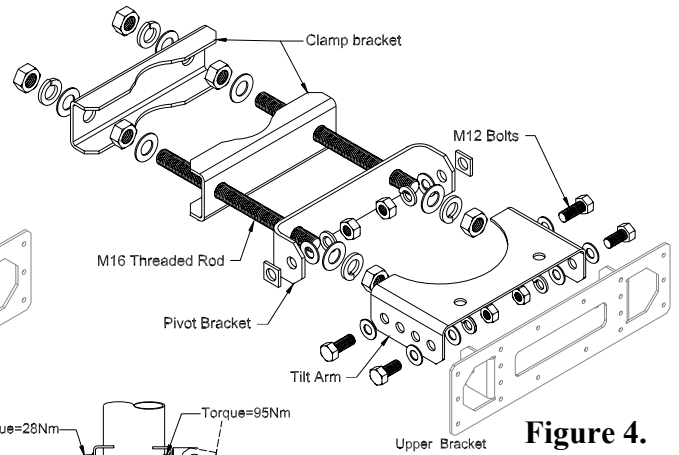

Figure 4.

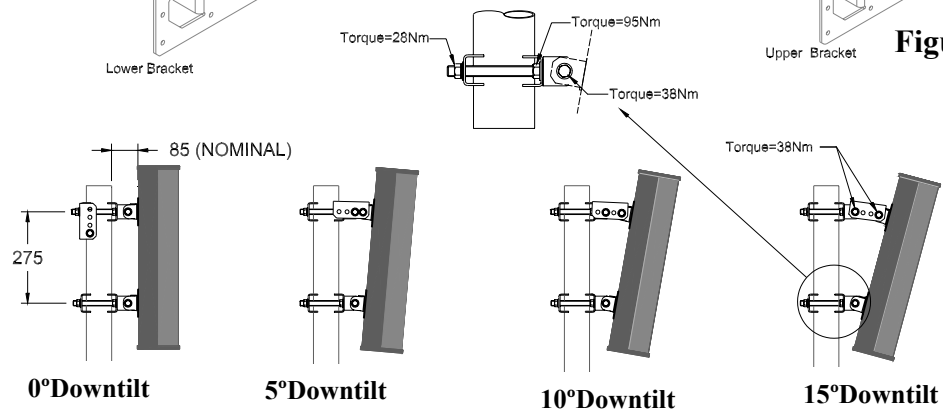

Figure 6.

Figure 4. Mechanically Adjustable Downtilt Top Bracket Exploded View
Figure 5. Mechanically Adjustable Downtilt Bottom Bracket Exploded View
Figure 6. Sample Antenna Positions Available With T-080-GL-E Kit

Installation Instructions - Mechanically Adjustable Downtilt Mounting Kits for 800 - 1100mm Antenna's (APM-T-045-GL-E)

Assemble both mounting brackets as per Figures 10 and 11 of this document.

1. Attach the lower and upper mounting bracket assemblies to the antenna, before trying to clamp the brackets to the pole.
2. Downtilt angles of 0° and 2° through to 10° in 1° increments can be obtained with the correct adjustment of the tilt arm bracket.
 - For 0° downtilt the tilt arm may be stowed as show in Figure 12.
 - 2°-10° downtilt can be achieved by aligning the corresponding hole in the tilt arm to the pivot bracket which mates against the mounting pole, as shown in Figure 12. The first hole is for 2° downtilt, with each consecutive hole resulting in an increased inclination of 1°.

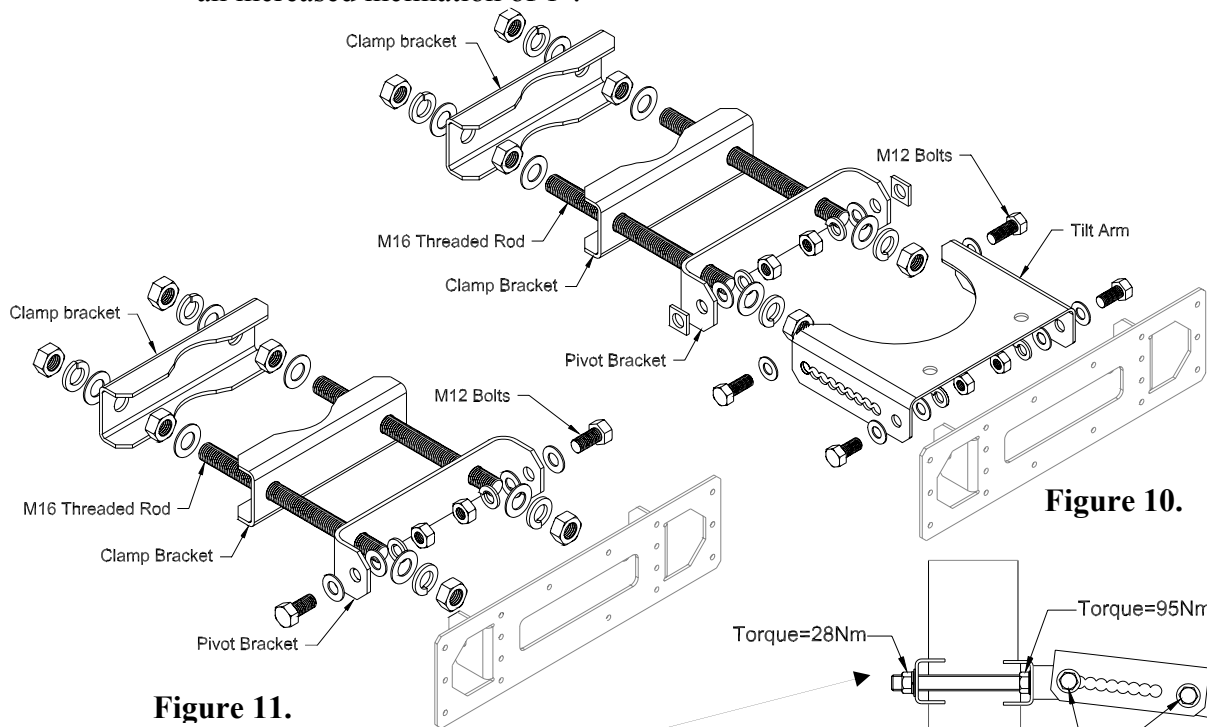
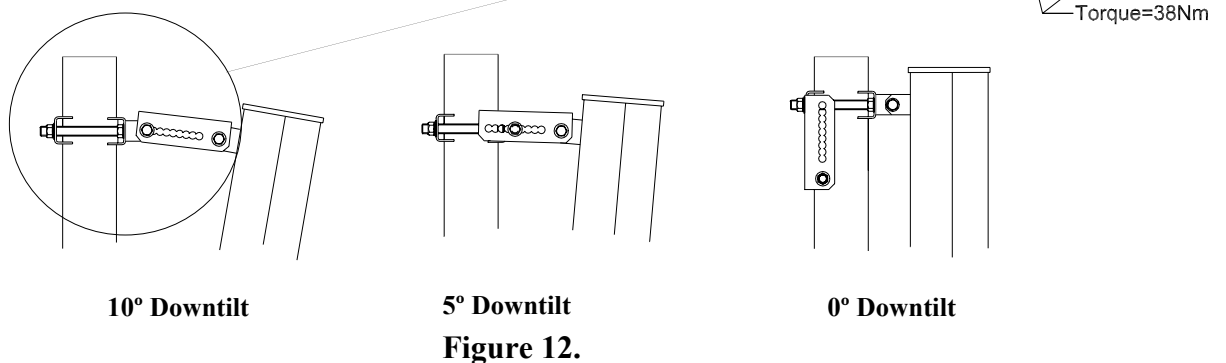

Figure 11.

Figure 10.



10° Downtilt

5° Downtilt

0° Downtilt

Figure 12.

Figure 10: Upper Mounting Bracket Exploded Assembly

Figure 11: Lower Mounting Bracket Exploded Assembly

Figure 12: Upper Bracket Placement For Various Downtilts

Installation Instructions - Mechanically Adjustable Downtilt Mounting Kits for 1100-1500mm Antenna's (APM-T-041-GL-E).

Assemble mounting brackets as per Figure 13 and Figure 14 of this document



1. Attach the lower and upper mounting bracket assemblies to the antenna, before trying to clamp the brackets to the pole.
2. Downtilt angles of 0° through to 12° in 2° increments can be obtained with the correct adjustment of the tilt arm bracket.
 - For 0° downtilt the tilt arm may be stowed as show in Figure 15.
 - 2°- 12° downtilt can be achieved by aligning the corresponding hole in the tilt arm to the pivot bracket which mates against the mounting pole, as shown in Figure 15. The first hole is for 2° downtilt, with each consecutive hole resulting in an increased inclination of 2°.

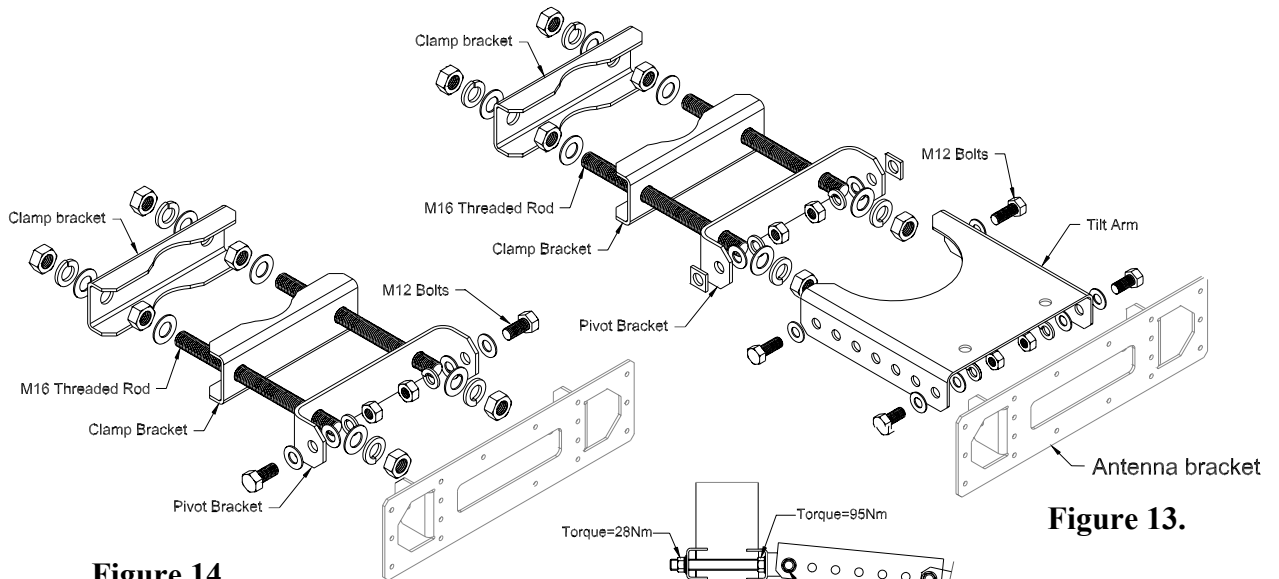

Figure 14.

Figure 13.

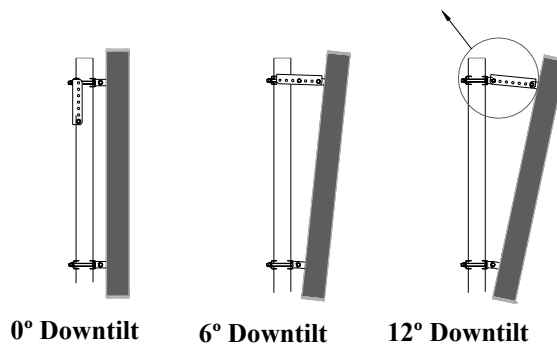

Figure 15.

**Figure 13. Upper Mounting Bracket Exploded Assembly.
Figure 14. Lower Mounting Bracket Exploded Assembly.
Figure 15. Upper Bracket Placement For Various Downtilts.**

Installation Instructions - Mechanically Adjustable Downtilt Mounting Kits for 1500-2700mm Antenna's (APM-T-029-GL-E).

Assemble mounting brackets as per Figure 17 and Figure 18 of this document



1. Attach the lower and upper mounting bracket assemblies to the antenna, before trying to clamp the brackets to the pole.
2. Downtilt angles of 0° through to 8° in 1° increments can be obtained with the correct adjustment of the tilt arm bracket.
 - For 0° downtilt the tilt arm may be stowed as show in Figure 19.
 - 1°- 8° downtilt can be achieved by aligning the corresponding hole in the tilt arm to the pivot bracket which mates against the mounting pole, as shown in Figure 19. The first hole is for 1° downtilt, with each consecutive hole resulting in an increased inclination of 1°.

Figure 16: Correctly Assembled Mounting Bracket for Mechanically Adjustable Downtilt Antenna

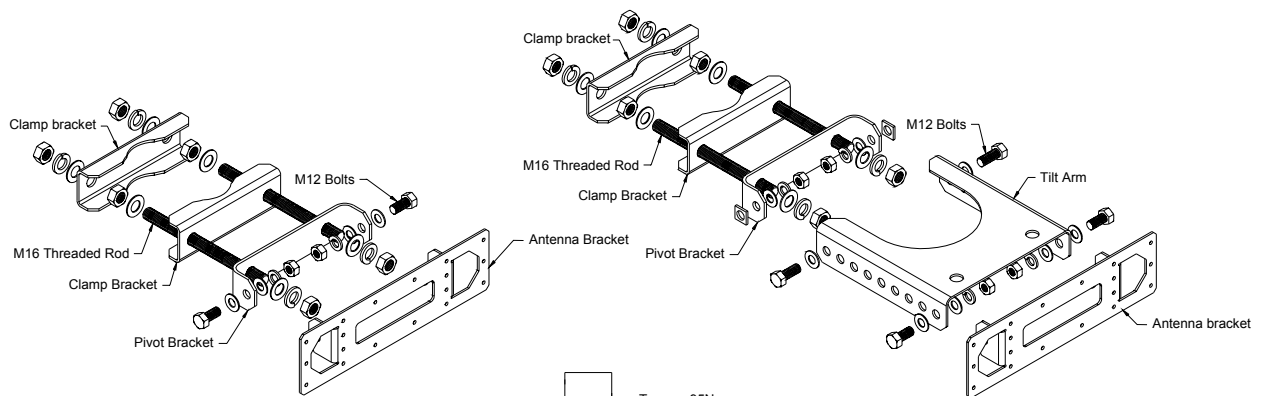

Figure 18.

Figure 17.

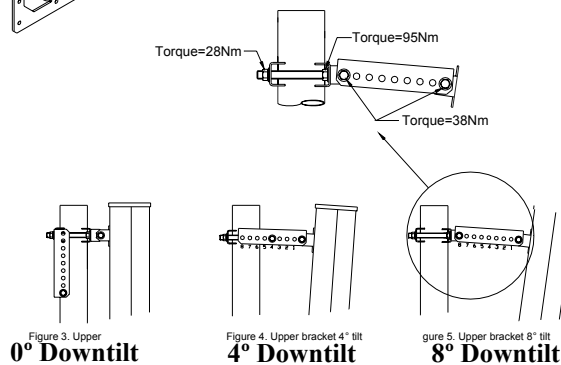

Figure 19.

Figure 17: Upper Mounting Brackets Exploded Assembly

Figure 18: Lower Mounting Bracket Exploded Assembly

Figure 19: Upper Bracket Placement For Various Downtilts

Operation of Antennas

Manual Electrically Adjustable Downtilt Antennas

The beam downtilt below the horizon is adjusted in the range of 0° to 10° by rotating the hex socket located at the bottom of the antenna (see Figure 20). Turning the hex socket in a clockwise direction increases the beam downtilt below the horizon. Turning the hex socket in an anti-clockwise direction decreases the beam downtilt below the horizon. Beam downtilt setting can be read off the scale at the base of the antenna.

AISG Compliant Adjustable Downtilt Antennas - Fitted with Remote Downtilt Adjustment

AISG Compliant antennas are compatible with AISG compliant control unit equipment, such as the RFS CNI-P2A20 AISG controller. For operation of downtilt using AISG compliant controllers see the controller documentation.



WARNING: During downtilt adjustment ensure the hex socket is not turned past the range of 0° to 10° as shown on the downtilt indicator scale. Forcing the hex adjustment beyond this point may lead to damage of the downtilt mechanism. Using power drills and electric screwdrivers to adjust downtilt may also lead to damage of the downtilt mechanism.



WARNING: Do not adjust the downtilt when the temperature is below -20° C. Adjustment below this temperature may lead to damage of the downtilt mechanism.

Figure 20: Single Band Antenna with connections labelled



**Figure 21: Dual Band
2500 MHz / 2500 MHz
or
3500MHz / 3500MHz Antenna with
connections labelled**

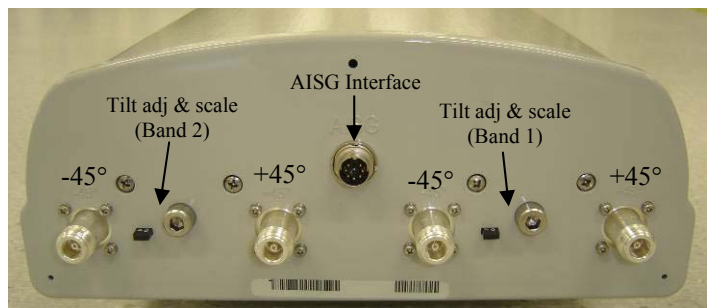
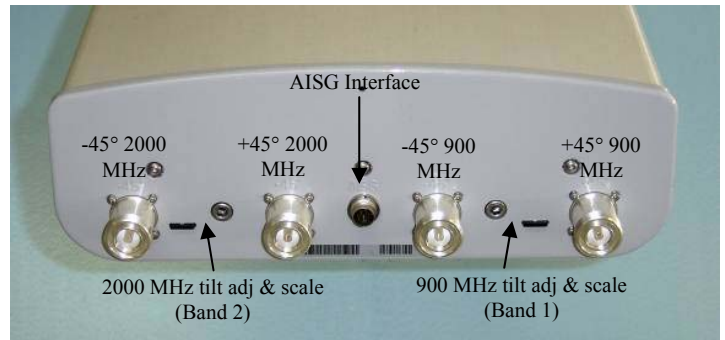

Figure 22: Dual Band 900 MHz / 2000 MHz Antenna with connections labelled



Figures 20, 21 and 22 show the configuration of the positive and negative slant polarization ports for single and multi band antennas. The tilt adjuster scale and port for remote interface is also highlighted.

Electrically Adjustable Downtilt Antennas – Indicator Scale

The downtilt angle in degrees below the horizon is read from the angle indicator scale. The downtilt scale is read from face of the antennas base plate at the point where the scale protrudes. As the downtilt is increased, the indicator scale protrudes further past the face, revealing further graduations of degrees.

Remote Electrical Tilt

AISG1.1: When using AISG1.1, a multiband antenna will report to the AISG1.1 controller as multiple antennas, each with a single band. Each band of the antenna will report a different serial number. For example, a tri band antenna with serial number 60051007 will report to the controller three individual antennas with serial numbers 600510071, 600510072, 600510073, where the last digit represents the band of the antenna.

AISG2: When using AISG2.0, a multiband antenna will report to the AISG2.0 controller as a single antenna with multiple bands. Each band of the antenna is accessible through the controller.

ANTENNA BANDS: In a dual band antenna, AISG band 1 is the RF low frequency band of the antenna. In a dual-band antenna with both RF bands operating in the same frequency spectrum, the antenna on the left when looking from behind the antenna is designated as AISG band 1. In a tri-band antenna, the RF low frequency band is designated as AISG band 1. The RF high frequency band closest to the base of the antenna is designated as AISG band 2 (as shown in Figure 25). The RF high frequency band closest to the top of the antenna is designated as AISG band 3.

SAFETY WARNING!

Transmitters connected to this antenna should be turned off prior to servicing / repairing or entering the near field of this antenna. ANSI (IEEE) C95.1-1999 Standard for Safety Levels with respect to human exposure to Radio Frequency Electromagnetic Fields 3KHz to 300GHz provides guidelines for determining the minimum protection distance from a radiating antenna in a controlled environment. Chart A below illustrates recommendations for minimum distance from VHF-UHF antennas vs. Effective Radiated Power (ERP). ERP is the total transmitter power into the antenna times the antenna power gain. (See Chart B)

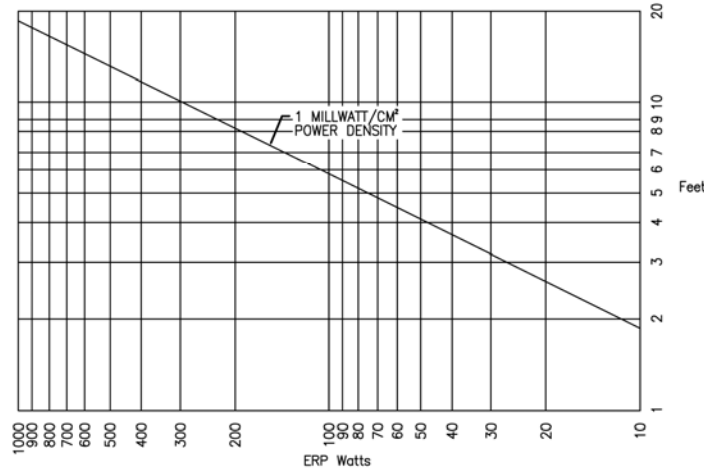

CHART A

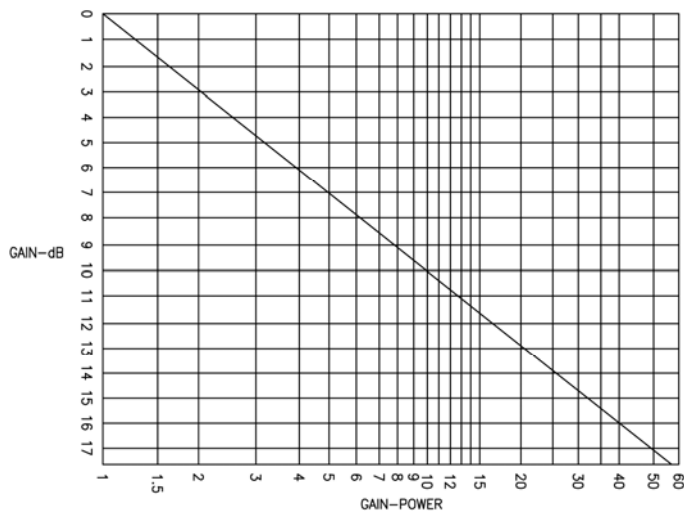

CHART B

These are theoretical calculations in free space with equal radiation in all directions. The actual mounting configuration terrain and antenna pattern may affect radiation intensity. If you require a detailed analysis of these specifics, RFS can provide a reference list of professional consultants. A list of companies providing field strength meters and test equipment is also available.

This product was designed and manufactured as a component of a professional communication system. It is intended to be installed by a professional installer. If you are not a professional installer, please contact your dealer for professional assistance.

**WARNING!
INSTALLATION
OF THIS PRODUCT
NEAR POWER LINES
IS DANGEROUS
FOR YOUR SAFETY;
FOLLOW THE
GENERAL SAFETY DIRECTIONS**

Each year, hundreds of people are killed, mutilated, or receive severe permanent injuries when attempting to install or remove an antenna. In many of these cases, the victim was aware of the danger of electrocution, but did not take adequate steps to avoid the hazard.

For your safety, and a proper installation, please READ and FOLLOW the safety precautions that follow – THEY MAY SAVE YOUR LIFE.

Save these instructions for future reference. The same precautions will apply when dismantling an antenna.

GENERAL SAFETY DIRECTIONS

1. Select your installation site with safety, as well as performance, in mind. Remember: **ELECTRIC POWER LINES, PHONE LINES AND GUY WIRES LOOK ALIKE. FOR YOUR SAFETY, ASSUME THAT ANY OVERHEAD LINES CAN KILL YOU.**
2. Call your electric power company. Tell them your plans and ask them to come look at your proposed installation. This is little inconvenience, considering **YOUR LIFE IS AT STAKE.**
3. Plan your installation procedure carefully and completely before you begin. Successful raising of a mast or tower is largely a matter of coordination. Each person should be assigned to a specific task, and should know what to do and when to do it. One person should be designated as the “boss” of the operation to call out instructions and watch for signs of trouble.
4. When installing your antenna, **REMEMBER:**
DO NOT use a metal ladder.
DO NOT work on a wet or windy day, especially during electrical storms or when there is thunder and lightning in the area.
DO dress properly – shoes with rubber soles and heels, rubber gloves, long sleeve shirt or jacket.
5. If the assembly starts to drop, get away from it and let it fall. **REMEMBER:** The antenna, mast, cable, and metal guy lines are excellent conductors of electrical current. Even the slightest touch of any of these parts to a power line completes an electrical path through the antenna and the installer – **THAT’S YOU!**
6. If any part of the antenna system should come in contact with a power line, **DON’T TOUCH IT OR TRY TO REMOVE IT YOURSELF. CALL YOUR LOCAL POWER COMPANY.** They will remove it safely.
7. If an accident should occur with the power lines: **DON’T** grab hold of the person in contact with the antenna and power line or you too will be electrocuted. Use a **DRY** board, stick or rope to push or pull the victim away from the antenna. If the victim has stopped breathing, administer artificial respiration – and stay with it. Have someone call for medical help.

RADIO FREQUENCY SYSTEMS



A-44965 REV 4, 08-DEC-03