

## Band IV/V (UHF) TV Panel Arrays

### Product Description

The PCP broadband panel is designed as a building block for integration into complex antenna arrays. It is a dual feed circularly or elliptically polarised UHF panel antenna. The panel can also be used individually for simple distributed or infill applications.

### Features

- Fully engineered for Digital TV, Mobile TV, Analogue TV and MIMO applications
- Corrosion resistant aluminium construction with fibreglass radome
- Independent inputs allowing utmost polarisation and pattern flexibility.
- Horizontal / Vertical, Circular or mixed polarization
- Low wind loading
- Hurricane rated
- High power rating
- Array design allows for custom design of horizontal and vertical radiation patterns
- Temperature range -40 to +60° C available

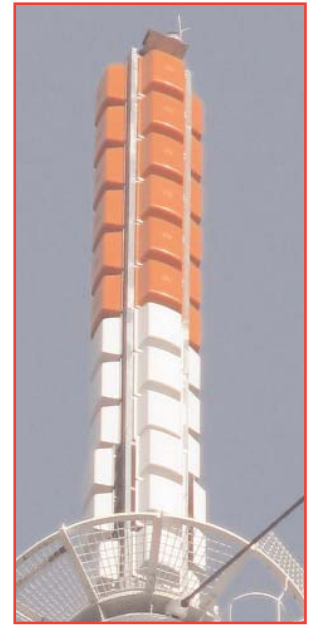

### Technical Features

MODEL	PCP-500
Product Type	Band IV/V (UHF) TV Panel Arrays
Frequency Range, MHz	470-560
Polarization	Horizontal / Vertical / Circular / Elliptical
Number of Channels	Multichannel
Nominal Gain (Mid-band, per plane), dBd	11-12
Nominal Half Power Beamwidth Azimuth, degrees	60
Antenna System Omni ripple	± 1.5 dB typical, ± 2.0 dB max
Return Loss, dB	26 min
Input Connector	2x 7/8" EIA Flange
Power Rating, kW	2.5 / input x 2
Impedance, Ohms	50 unbalanced
Weight, kg (lb)	14.5 (32)
Mounting (Standard), mm (in)	4 x 10mm (3/8) bolts
Effective Area Front (full antenna), sq m (sq ft)	0.45 (4.84)
Effective Area Side (full antenna), sq m (sq ft)	0.35 (3.76)
Design Wind Speed ( max), km/h (mph)	240 (150)
Colour	White radome standard, other upon request
Pressurization - Operational, kPa (psi)	7 - 21 (1 - 3)
Pressurization - Test, kPa (psi)	100 (15)
Material - Insulators	PTFE
Material - Radiators	Corrosion resistant aluminium
Material - Reflecting Screen	Corrosion resistant aluminium



Band IV/V (UHF) TV Panel Arrays

Antenna Array Specifications

Number of bays (levels)	1				2				4			
	1	2	3	4	1	2	3	4	1	2	3	4
Panels per bay	1	2	3	4	1	2	3	4	1	2	3	4
Vertical Spacing between Bays (m)	1.15	1.15	1.15	1.15	1.15	1.15	1.15	1.15	1.15	1.15	1.15	1.15
HRP Directivity Hpol (dB)	7.51	4.28	2.61	1.68	7.51	4.28	2.61	1.68	7.51	4.28	2.61	1.68
VRP Directivity (dBd)	3.94	3.94	3.94	3.94	6.99	6.99	6.99	6.99	9.49	9.49	9.49	9.49
Gain Hpol component (dBd)	11.5	8.2	6.6	5.6	14.5	11.3	9.6	8.7	17.0	13.8	12.1	11.2
Gain (times)	13.96	6.64	4.52	3.65	28.18	13.40	9.12	7.36	50.12	23.82	16.22	13.09
Weight (kg)	14	74	96	118	104	148	192	236	208	296	384	472
Weight (lbs)	31	163	212	260	229	326	423	520	459	653	847	1041
Antenna Aperture L (m)	1.2	1.2	1.2	1.2	2.3	2.3	2.3	2.3	4.6	4.6	4.6	4.6
Antenna Aperture L (ft)	3.8	3.8	3.8	3.8	7.5	7.5	7.5	7.5	15.1	15.1	15.1	15.1
Effective area (m2)	1.0	1.2	1.6	1.6	2.0	2.8	5.5	5.5	4.1	4.8	10.2	10.2
Effective area (ft2)	11.0	12.7	17.0	17.0	22.1	29.7	59.5	59.5	44.2	51.8	110.4	110.4
Windload @ 50m/s (kN)	1.6	1.8	2.4	2.4	3.1	4.2	8.4	8.4	6.3	7.3	15.6	15.6
Windload @ 50m/s (lbs)	352	406	541	541	704	947	1894	1894	1407	1651	3518	3518

Number of bays (levels)	8				12				16			
	1	2	3	4	1	2	3	4	1	2	3	4
Panels per bay	1	2	3	4	1	2	3	4	1	2	3	4
Vertical Spacing between Bays (m)	1.15	1.15	1.15	1.15	1.15	1.15	1.15	1.15	1.15	1.15	1.15	1.15
HRP Directivity Hpol (dB)	7.51	4.28	2.61	1.68	7.51	4.28	2.61	1.68	7.51	4.28	2.61	1.68
VRP Directivity (dBd)	12.49	12.49	12.49	12.49	14.23	14.23	14.23	14.23	15.48	15.48	15.48	15.48
Gain Hpol component (dBd)	20.0	16.8	15.1	14.2	21.7	18.5	16.8	15.9	23.0	19.8	18.1	17.2
Gain (times)	100.00	47.53	32.36	26.12	149.28	70.96	48.31	38.99	199.07	94.62	64.42	52.00
Weight (kg)	416	592	768	944	624	888	1152	1416	832	1184	1536	1888
Weight (lbs)	917	1305	1693	2082	1376	1958	2540	3122	1835	2611	3387	4163
Antenna Aperture L (m)	9.2	9.2	9.2	9.2	13.8	13.8	13.8	13.8	18.4	18.4	18.4	18.4
Antenna Aperture L (ft)	30.2	30.2	30.2	30.2	45.3	45.3	45.3	45.3	60.4	60.4	60.4	60.4
Effective area (m2)	8.2	9.7	19.7	19.7	12.6	14.9	28.3	28.3	16.5	19.7	38.5	38.5
Effective area (ft2)	88.4	104.5	212.4	212.4	135.9	161.4	305.9	305.9	178.4	212.4	416.3	416.3
Windload @ 50m/s (kN)	12.5	14.8	30.1	30.1	19.3	22.9	43.3	43.3	25.3	30.1	59.0	59.0
Windload @ 50m/s (lbs)	2814	3328	6765	6765	4329	5141	9741	9741	5682	6765	13258	13258

- Note 1: For antenna systems with 1 or 2 panels per bay, load calculations include a mounting pipe/pole 60-90mm OD.
- Note 2: For antenna systems with 1 or 2 levels, load calculations include a mounting pipe/pole 60-90mm OD
- Note 3: For antenna systems with 3 or 4 panels per bay, and 4 to 16 levels/bays, load calculations include a 640 x 640mm square spine/column.
- Note 4: Interface steelwork antenna system to tower is not included in load calculations.
- Note 5: Gains shown are for single polarisation only. Assuming the array is used as circularly polarised, a reduction in system gain of 3dB must be included in ERP calculations.

Antenna Panel Dimensions

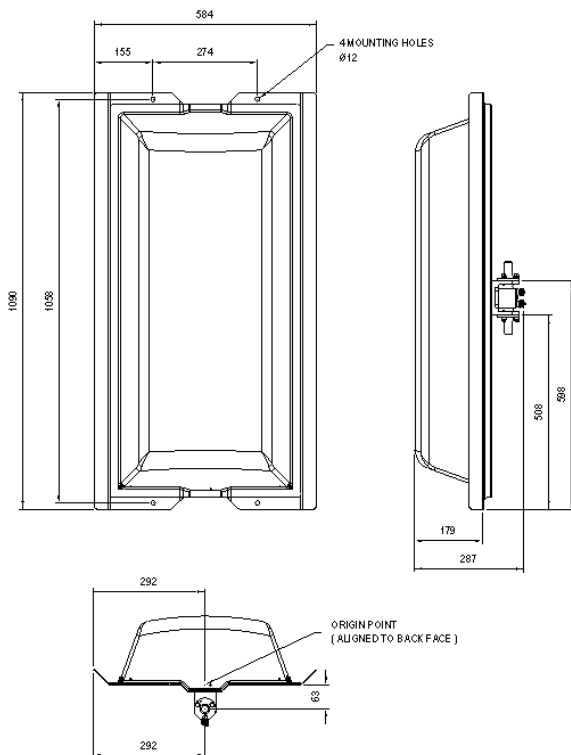

Nomenclature

Equal Split

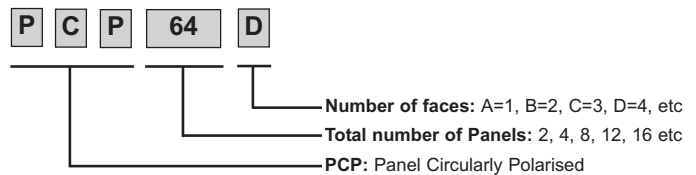

Unequal Split

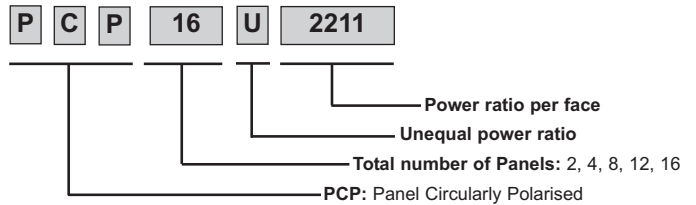

Thinned array

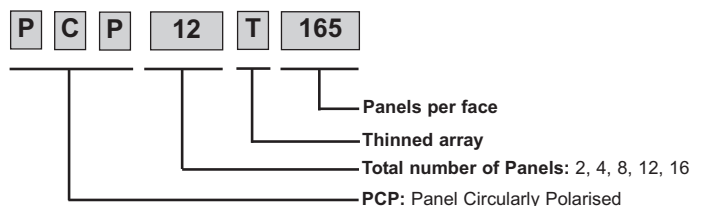

All information contained in the present brochure is subject to confirmation at time of ordering

Band IV/V (UHF) TV Panel Arrays

Horizontal patterns

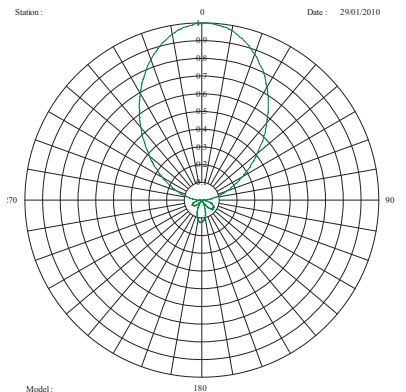
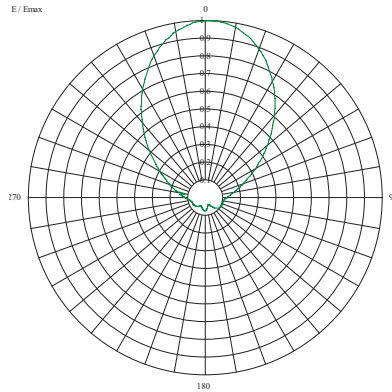
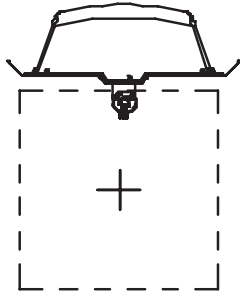

HRP VPOL PCP500-A 7.14dBd

HRP HPOL PCP500-A 7.4dBd

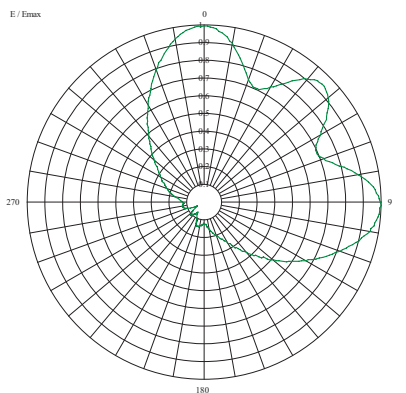
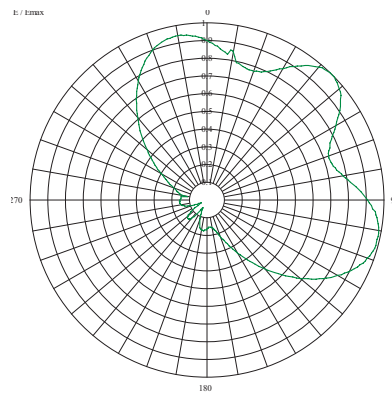
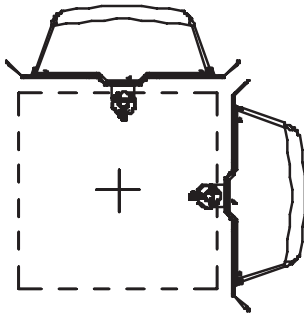

HRP VPOL PCP500-B 4.06dBd

HRP HPOL PCP500-B 4.6dBd

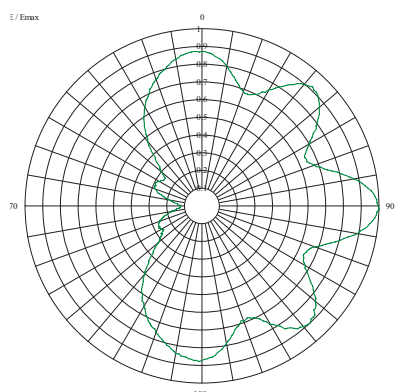
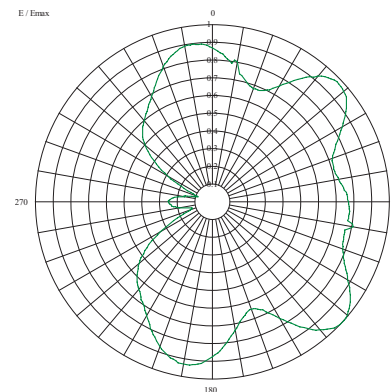
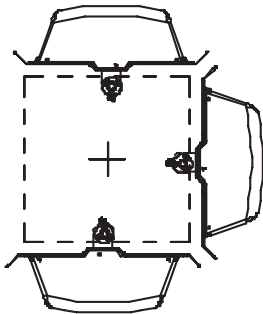

HRP VPOL PCP500-C 2.9dBd

HRP HPOL PCP500-C 3.32dBd

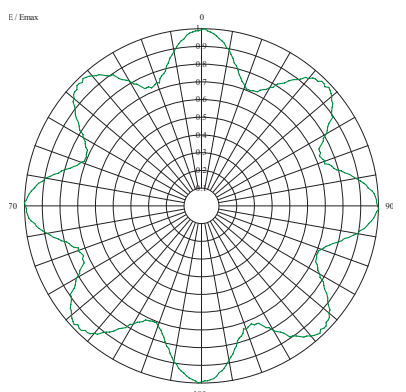
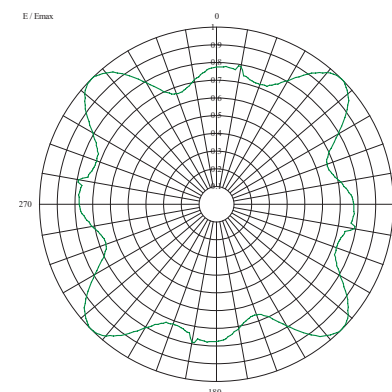
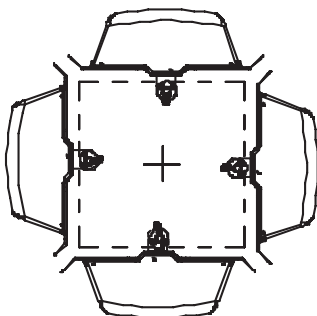

HRP VPOL PCP500-D 1.9dBd

HRP HPOL PCP500-D 1.30dBd

All information contained in the present brochure is subject to confirmation at time of ordering

Band IV/V (UHF) TV Panel Arrays

Vertical patterns

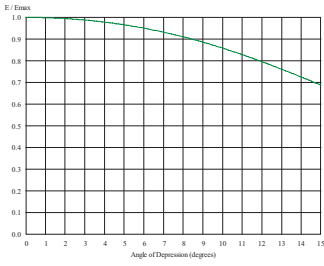

VRP HPOL PCP500-1 3.75dBd

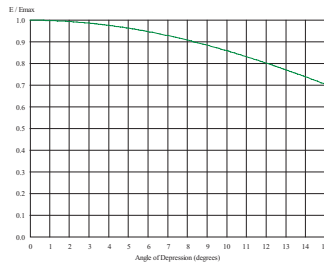

VRP VPOL PCP500-1 3.54dBd

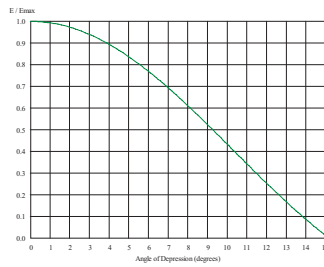

VRP HPOL PCP500-2 6.67dBd

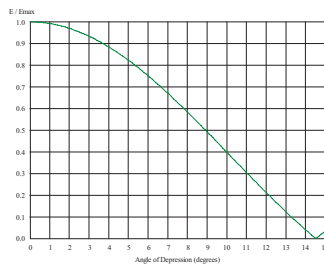

VRP VPOL PCP500-2 6.54dBd

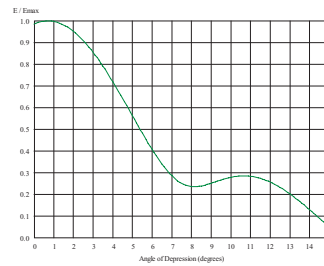

VRP HPOL PCP500-4 9.11dBd

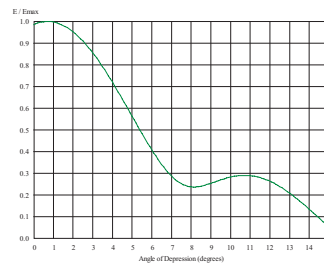

VRP VPOL PCP500-4 9.03dBd

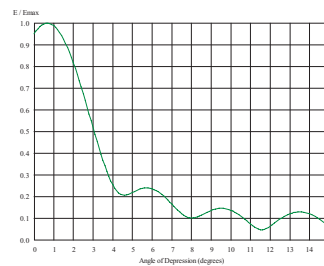

VRP HPOL PCP500-8 12.09dBd

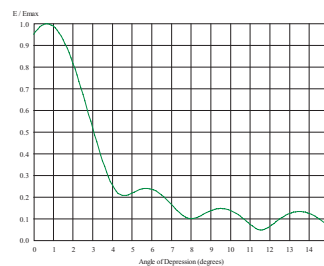

VRP VPOL PCP500-8 12.03dBd

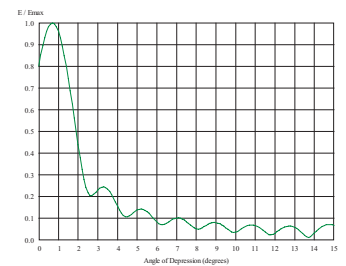

VRP HPOL PCP500-16 15.05dBd

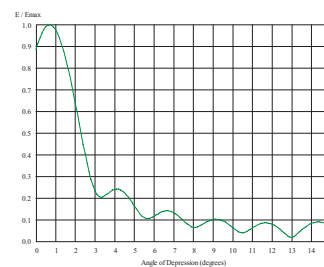

VRP HPOL PCP500-12 13.81dBd

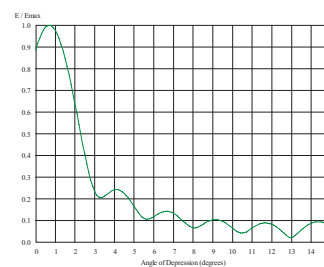

VRP VPOL PCP500-12 13.77dBd

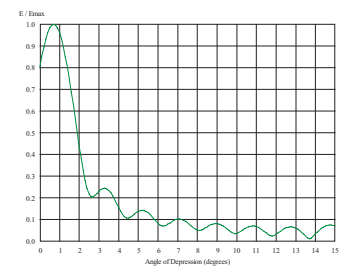

VRP VPOL PCP500-16 15.01dBd

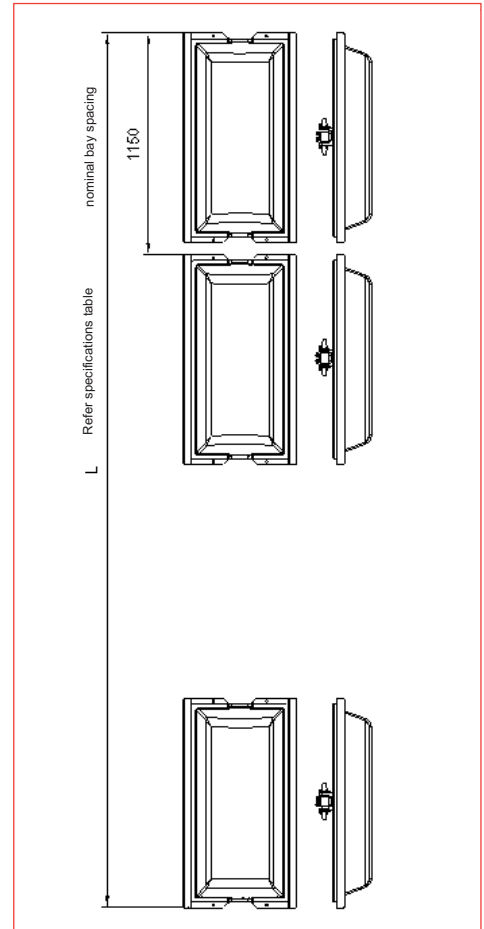

All information contained in the present brochure is subject to confirmation at time of ordering