

# SC1/SCX1 ANTENNA

Installation Instructions

Offset left

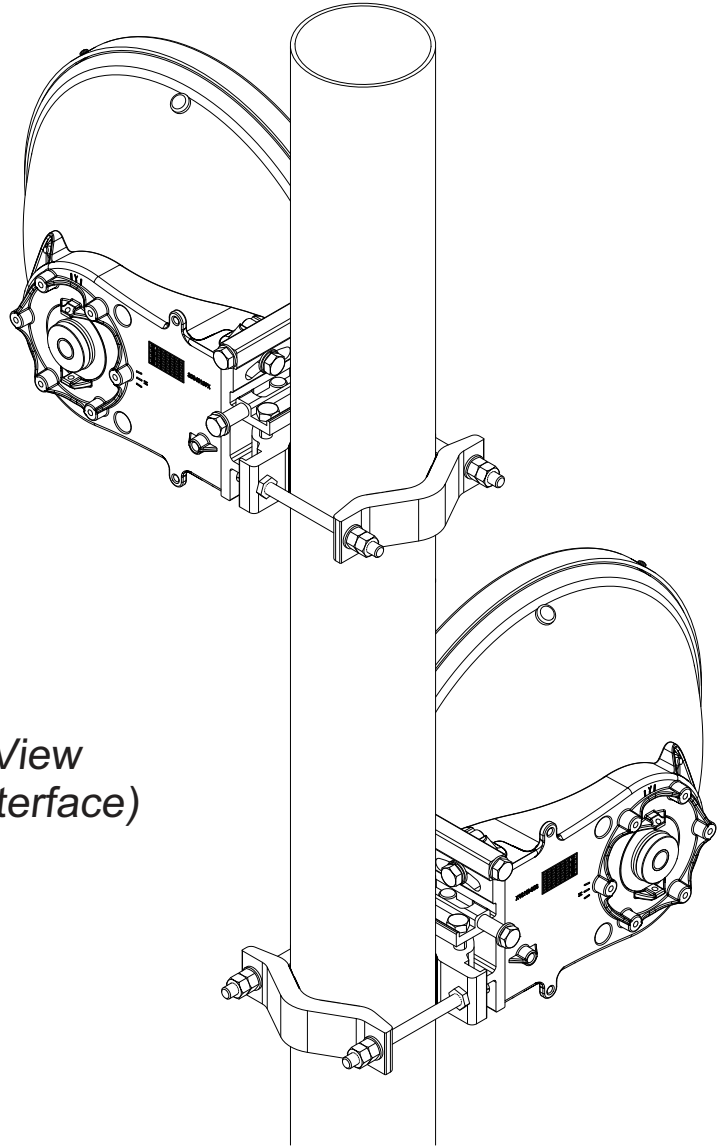

Generic View  
(Standard Interface)

Offset right

## Required tools

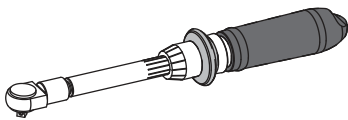

3...45N.m

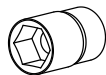

10/17

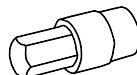

4

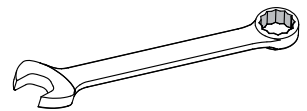

10/17

It is important to mount the antenna exactly as described in this installation instruction.  
 The installed antenna shall be inspected once per year by qualified personnel.  
 RFS disclaims any responsibility for the result of improper or unsafe installation.  
 This installation instruction has been written for qualified, skilled personnel.

We reserve the right to alter details, especially with respect to technical improvement

# SC1/SCX1 ANTENNA

Installation Instructions



2 / 2

NMT-10-1134-01

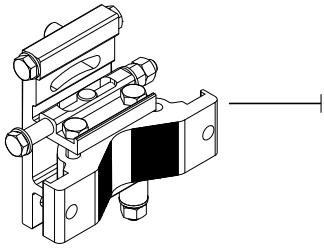

Mount | x1

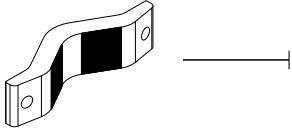

Clamp | x1

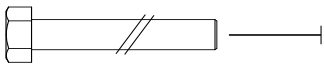

M10x140 | x2



M10x30 | x3

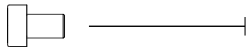

M8x10 | x1

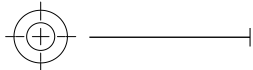

Washer A10,5 | x5

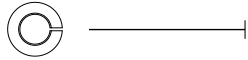

Washer W10 | x3

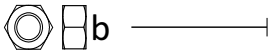

Nut M10 | x4

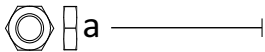

Nut M10 | x2

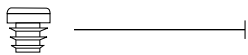

Rain cap | x1



Grease | x1

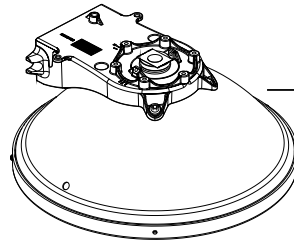

Reflector + feed | x1

Customer Interface

