



Radio Frequency Systems



**APM40-5E MOUNTING KIT
INSTALLATION INSTRUCTIONS**

REV. 3 | 2021.05



Mounting Instructions for APM40-5E Kit

SUMMARY

1. Application	3
2. Features	3
3. Mechanical Specifications	3
4. Tools required for installation	4
5. Item numbers for the Mount Kit Hardware.....	4
6. Assembly of components to antenna	4
7. Adjusting the tilt with short beam assembly	8
8. Tightening torque values	9
9. Bracket Separation.....	9
10. Maintenance	9

Mounting Instructions for APM40-5E Kit

1. APPLICATION

The APM40-5E Mounting Kit is a mounting hardware which uses mounting interface brackets as shown below. If the E10T bracket was shipped in a separate box with the antenna, please attach it first.

1. Attach interface bracket to antenna with M8 hardware where required.
2. The installation of Top and Bottom interface are same.

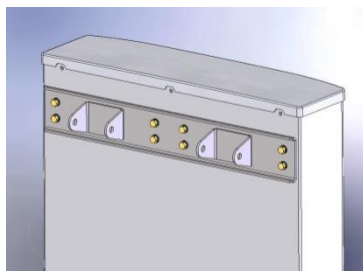
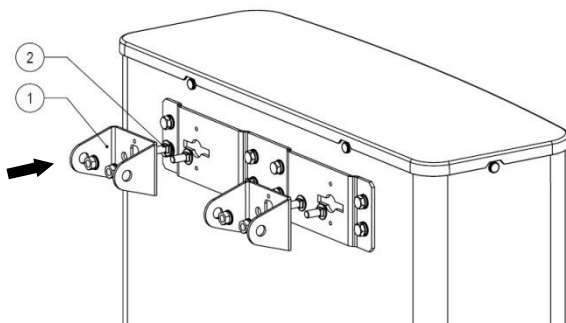

Top

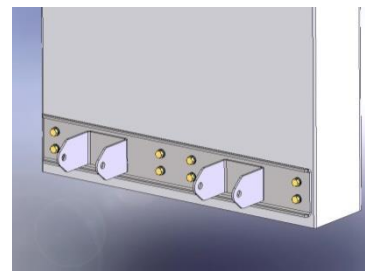

Bottom

2. FEATURES

- Beam sliding tilt mount for mechanical tilt
- Pipe diameter: 60-120mm
- Mechanical downtilt: 0~9° for 2.0m~2.6m antennas

3. MECHANICAL SPECIFICATIONS

Weight of Kit (kg)	11.5
Mounting Kit Material	Aluminum, Galvanized Steel
Packaging Dimensions, H x W x D (mm)	710 x 530 x 90
Packaging Material	Plastic Sleeve

Please contact technical support for more information.

Mounting Instructions for APM40-5E Kit

4. TOOLS REQUIRED FOR INSTALLATION

- 13mm, 18mm and 19mm (3/4") AF Spanner or Socket (3/8" drive recommended)
- Torque wrench

5. ITEM NUMBERS FOR THE MOUNT KIT HARDWARE

ITEM#	DESCRIPTION	QUANTITY
1	Clamp front 800Mhz	2
2	Clamp rear 800Mhz	2
3	M12-200, Galvanized, DIN603 / ISO8677, class 8.8	4
4	Screw H M12x110 CS 35K 8.8 GVRO ISO4017	8
5	Washer FL 13x24x2.5 CS 200HV GVRO GB97	12
6	Washer SP 12x3.5 65Mn 200HV GVRO GB7244	12
7	Nut H M12x19x10 CS 35K 8 GVRO DIN934	12
8	Stub for scissor	4
9	Downtilt scissor	2
10	Downtilt beam	2
11	Mechanical downtilt indicator 800Mhz 2.6m	2
12	Stub Spacer 3mm	2
13	M8-100, Galvanized, ISO8677, class 4.8	4
14	SPRING LOCK WASHER A8 DIN127 A2	4
15	FLAT WASHER DIN125 8.4 A2 (FRTR)	4
16	M8X1,25 HEX NUT STL GALV	4
17	Spacer for bottom mounting	4

6. ASSEMBLY OF COMPONENTS TO ANTENNA

Due to the heavy weight of the antenna and in order to have better, safer and easier assembly, the operator can preassemble all the parts together on the ground according to the detailed view below. During the preassembly, all the fixations shall be assembled but not fully tightened, extreme caution to be used that all nuts bolt and washers are fitted according to the assembly diagram before lifting can take place. Then use lifter to lift the antenna to the correct pole side, this will enable ease of installation.

For the lifting point's selection, item 1 on the top and bottom is the right part to use. The operator can put the lifting tool on these two parts to lift the antenna.

Mounting Instructions for APM40-5E Kit

After attached the antenna with the pole, all the fixation should be locked tightly according to the required torque specification [refer torque table].

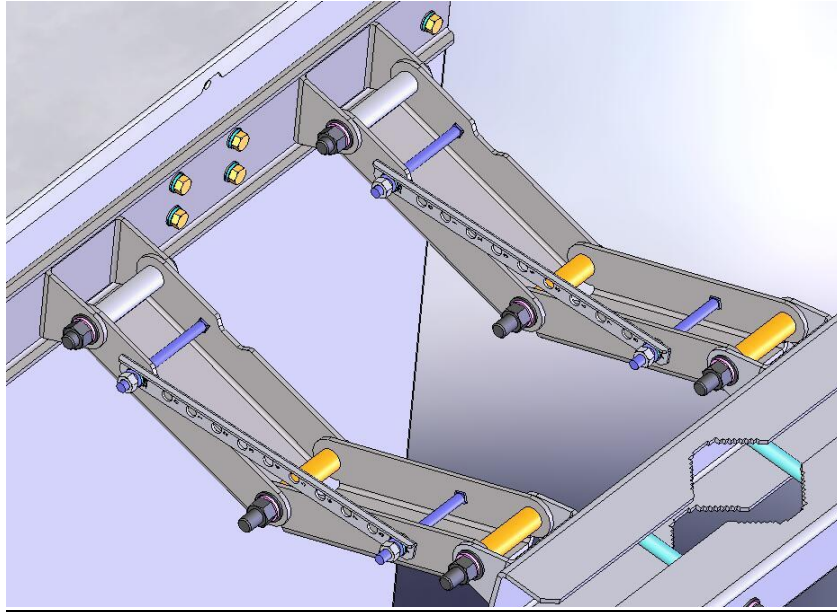

Detailed left view for top mounting kits

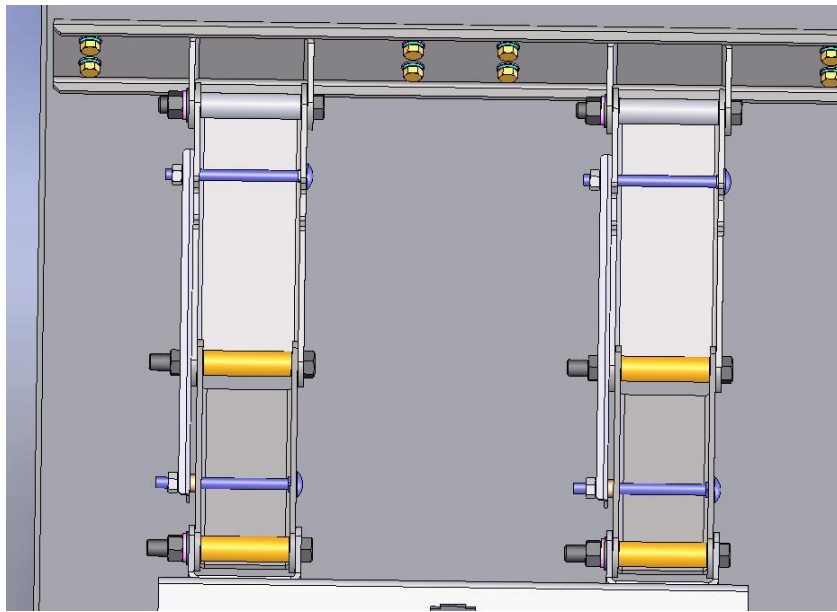

Detailed middle view for top mounting kits

Mounting Instructions for APM40-5E Kit

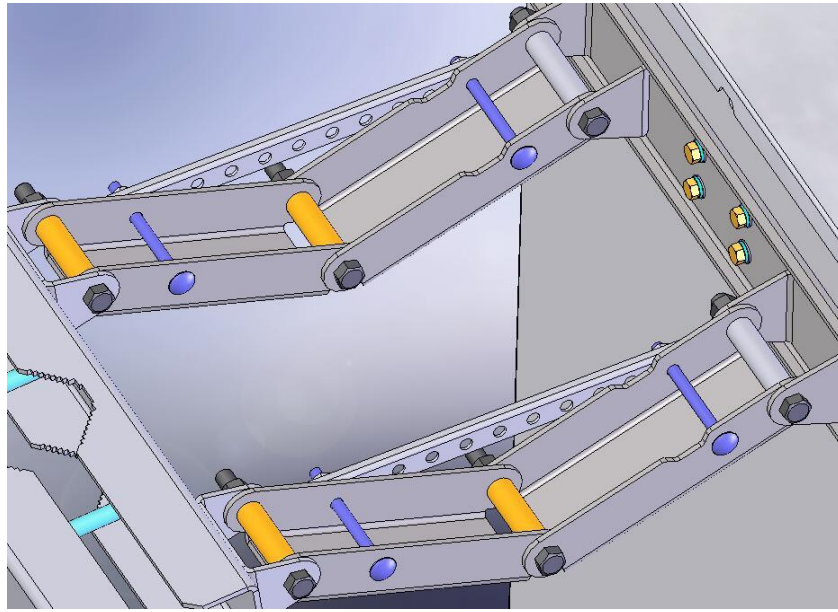

Detailed right view for top mounting kits

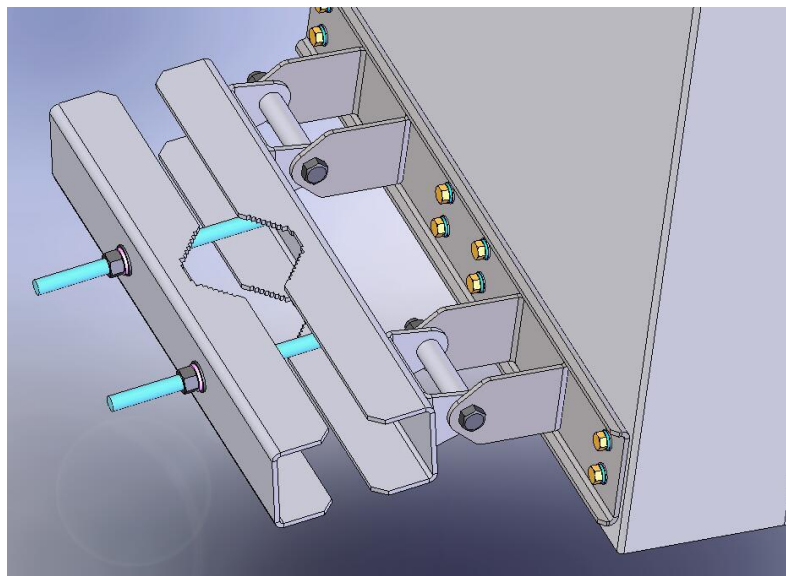

Detailed view for bottom mounting kits

Mounting Instructions for APM40-5E Kit

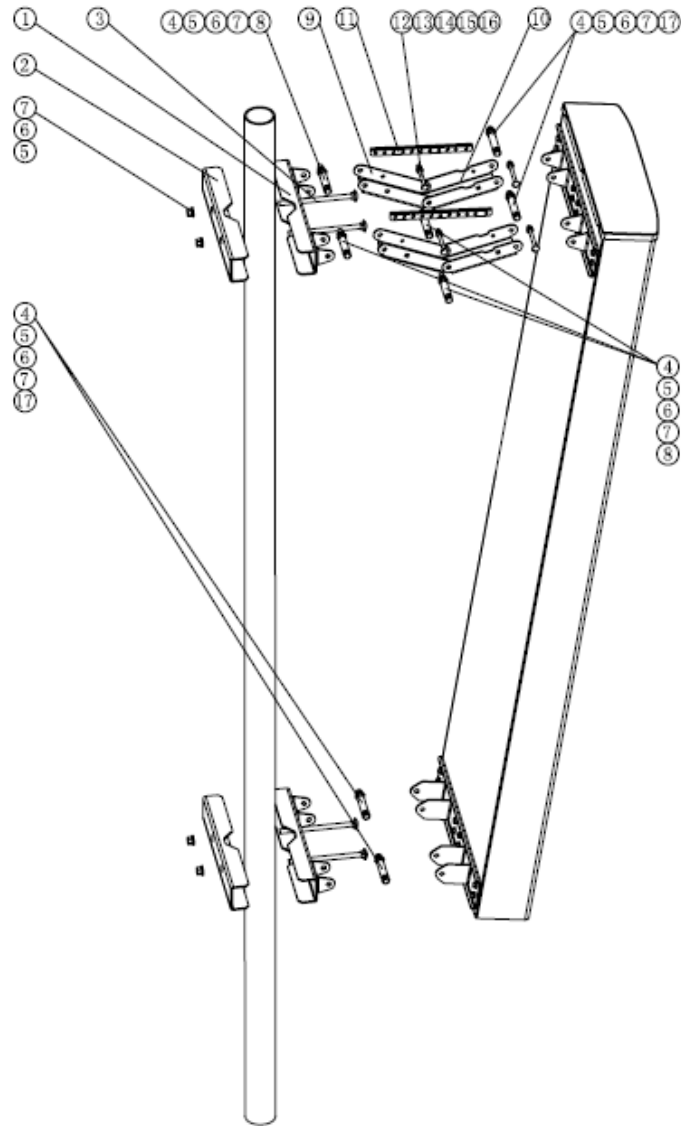

Beam Tilt Assembly for downtilt

This assembly attaches pipe to top of antenna. Ensure tilt indicator has SHORT BEAM tilt markings visible.

Mounting Instructions for APM40-5E Kit

7. ADJUSTING THE TILT WITH SHORT BEAM ASSEMBLY

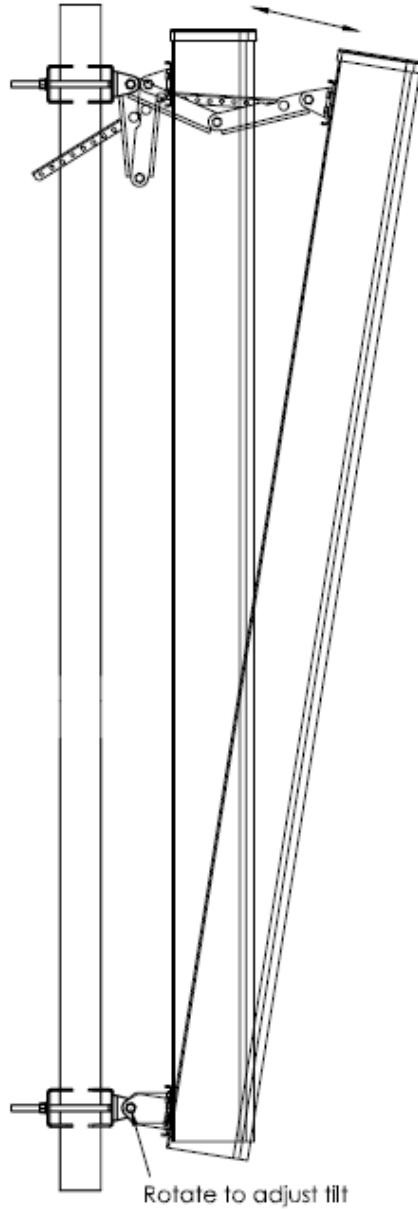

To adjust tilt, loosen pipe clamp bolts, bolts through tilt beams and bolt at antenna bracket base (as shown by arrows). Slide arms up or down pipe to achieve tilt. Align mark with indicator angle. Tighten nuts to lock in position.

Mounting Instructions for APM40-5E Kit

8. TIGHTENING TORQUE VALUES

Unless otherwise stated, the following general tightening torque values shall be used for metric hexagon bolts and screws, coarse pitch threads, property class 8.8.

Diameter	Pitch (mm)	Bolt Tension (kN)	Torque (Nm)
M12	1.75	23.8	60
M8	1.25	9.5	16

9. BRACKET SEPARATION

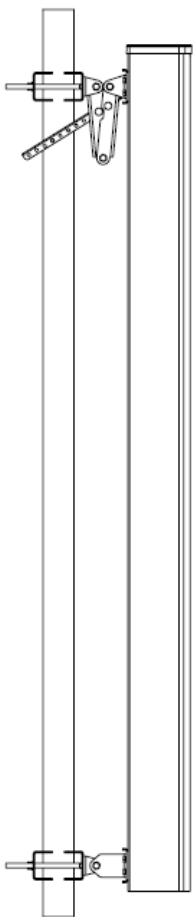

0° Tilt

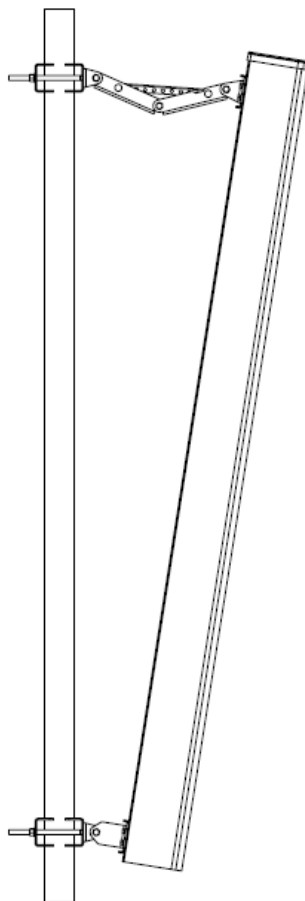

9° Tilt

10. MAINTENANCE

About RFS

Radio Frequency Systems (RFS) delivers the end-to-end RF solutions and expert services needed to evolve wireless and broadcast networks today and tomorrow. Our cables, connectors, antenna systems and RF conditioning products are based on more than 120 years of experience delivering cutting-edge RF solutions and industry firsts. As a result, our solutions are recognized globally for their innovation, superior performance and unmatched quality.

As an ISO-compliant company with global operations, we bring our customers world-class engineering and manufacturing skills backed with comprehensive local support services. Our customers know they can rely on our expertise and commitment to excellence from initial design to final delivery and beyond — whether they're looking to support 5G, deploy small cells, empower smart cities or improve indoor coverage in the most challenging locations.

Australia

Kilsyth
+61 3 9751 8400
Technical Support
Technical.Support@rfsworld.com

Latin America

Sao Paulo
Technical Support
MTS.Latam@rfsworld.com

China

Shanghai
+86 21 3773 8888
Technical Support
Technical.Support@rfsworld.com

France, Italy, Spain

Paris, Vimercate, Madrid
Technical Support
Product.Support@rfsworld.com

Germany

Hannover
+49 511 676 55 - 0
Technical Support
Product.Support@rfsworld.com

India

Gurgaon
+91-124-4092788
Technical Support
Technical.Support@rfsworld.com

North America

Meriden, CT
+1.800.321.4700
Technical Support
ApplicationsEngineering@
rfsworld.com

Mexico

Tlalnepantla de Baz
+52 55 2881-1100
Technical Support
MTS.Latam@rfsworld.com

Russia

Moscow
Technical Support
Product.Support@rfsworld.com

UAE

Dubai
+971 4 568 7979
Technical Support
Product.Support@rfsworld.com

United Kingdom

Haddenham
+44 1844 294900
Technical Support
Product.Support@rfsworld.com