



Radio Frequency Systems line of high performance HELIFLEX® coaxial cable connectors are characterized by excellent gas tightness and extremely low losses. HELIFLEX®Lite connectors can be installed with basic hand tools, but the use of dedicated installation tools further facilitates ease of assembly and improves performance.

RFS connectors are fully tested for mechanical and electrical compliance specifications. HELIFLEX®Lite premium connectors have excellent electrical values and provide outstanding performance for the most demanding applications. The RFS connector design provides maximum sealing integrity and gas tightness.

FEATURES / BENEFITS

- Easy installation utilizing only basic hand tools.
- Tab flare of outer contact attachment means quick and simple installation.
- No need for sealing compound. The connector is ready for pressurization immediately after installed to the cable.
- Excellent gas tightness. Overpressure for increased voltage handling is maintained throughout the system.
- Outstanding VSWR performance improves overall system performance.
- Totally waterproof, assures safe, long term operation in the harshest of environments.
- RoHS (EU) and CRoHS (China) compliant, can be used on a global basis.



Connector 4-1/2" IEC

Technical features

GENERAL SPECIFICATIONS

Transmission Line Type		Coaxial Cable
Cable Size		5-1/2"
Cable Type		Air Dielectric
Model Series		HCA550-50 Series
Connector Interface		4-1/2" EIA (50 Ω) per IEC 60339-2
Connector Type		Gas stop / Gas pass - See Note 1.
Sealing Method		O-ring seal
Gender		Female - See Note 2.

ELECTRICAL SPECIFICATIONS

Connector Frequency Range	GHz	DC - 860MHz
VSWR, Return Loss	VSWR (dB)	DC - 860MHz: 1.02 (40)

MECHANICAL SPECIFICATIONS

Plating Outer/Inner		silver
Length	mm (in)	254.2 (10.008)
Outer Diameter	mm (in)	212 (8.346)
Weight	kg (lb)	16 (35.274)
Body Material		copper alloy / nickel plated
Inner Contact Material		copper alloy / silver plated

TESTING AND ENVIRONMENTAL

Waterproof Level		IP68 (pressure-tight up to 4 bar / 400 kPa)
STORAGE TEMPERATURE CF	°C (°F)	-70 to 85 (to)
OPERATION TEMPERATURE CF	°C(°F)	-40 to 85 (to)

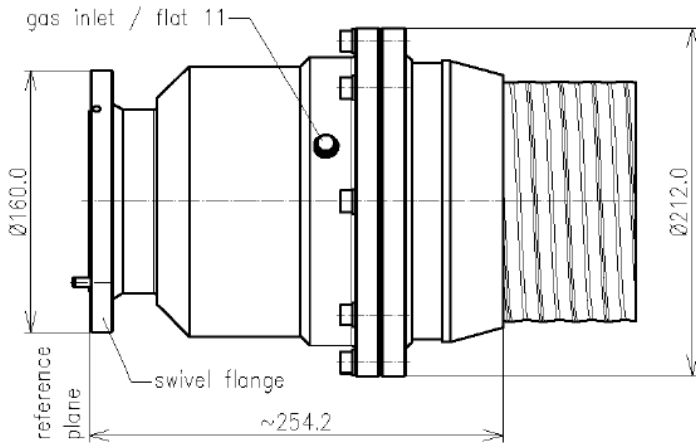

External Document Links

[Installation instruction for HCA495 / HCA550 / HCA618 *-019 connector series](#)

Notes

1. The connector is converted to gas pass by drilling through the pilot hole in the insulator.
2. Connector does not include an inner connector.
3. Gas inlet: NPT1/8"
4. Peak power capability: 2250 kW
5. Average power capability (at 40°C ambient temperature): 37.0 kW @ 860 MHz
6. Proof voltage, max.:15.0 kV