



The 903 series is designed as a building block for broadband high power FM arrays for broadcasting in the FM Band (87.5 - 108 MHz). The 903 series is designed for use on triangular cross section masts.

The 903CP panel comprises two crossed dipoles mounted off a reflective screen. This configuration allows circular polarization. The 903HP comprises two horizontal dipoles mounted off a reflective screen for horizontal polarization. Similarly the 903VP comprises two vertically mounted dipoles off a reflective screen for vertical polarization.

In some configurations the dipoles are angled towards the screen reducing backlobes and making the panel ideal as an array element on 3 sided towers or masts.

The design utilizes stainless steel radiators with galvanized screen and ensures a very long trouble free life, even when installed in remote hostile environments.

The 903 panels can be arranged to provide the required coverage for a particular service area. Array design can be carried out by RFS engineers. Both directional and omnidirectional patterns are available as well as beam tilt and null fill to customer specification. Panels are fed through a power divider network which is designed to meet the power handling requirements of the array. As each panel is rated at 2 x 5kW, higher power ratings are easily achievable. The system should be fully pressurized in a high power configuration. For low to medium power applications a power distribution and cable network utilizing foam feeders and un-pressurized power dividers is available.

FEATURES / BENEFITS

- Full band (87.5 - 108MHz) operation
- Low cost alternative to the 4 sided antenna
- Low VSWR
- Suitable for multichannel use
- Circular polarization
- Two inputs per panel
- Available in pressurized or unpressurized versions
- Solid galvanized steel screen construction
- Dipole elements are stainless steel
- Cyclone rated
- Designed for minimum windload
- Radomes and special 'O' rings available for icing conditions
- Temperature range -40 to +60 degrees C available.



903CP Series showing 903CP-2 Antenna

Technical features

STRUCTURE

Product Line		Antenna TV
Product Type		Band II (VHF) 903CP FM Panel Arrays

ELECTRICAL SPECIFICATIONS

Frequency Range	MHz	87.5 - 108
Polarization		Circular
Nominal Gain (Mid-band)	dBd	3.5
Gain per Plane of Polarization	dBd	3.5
Return Loss	dB	20
Power Rating	kW	Note 1
Impedance (unbalanced)	Ω	50



MECHANICAL SPECIFICATIONS

Input Connector		2 x 7-16 DIN 2 x 7/8" EIA Flange
Mounting (Standard)	mm (in)	4 x M12 x 80mm (3.1) bolts
Recommended Spacing between Bays	cm (in)	280 (108)
Effective Area Front (full antenna) No Ice	m ² (ft ²)	1.0 (10.8)
Effective Area Side (full antenna) No Ice	m ² (ft ²)	0.65 (7.00)
Design Wind Speed	km/h (mph)	240 (150)
Pressurization Operational	kPa (psi)	10 - 25 (1.5 - 3.6) 7/8" EIA Version
Pressurization Test	kPa (psi)	100 (15) 7/8" EIA Version
Weight	kg (lb)	61 (135)

PACKAGING INFORMATION

Shipping Weight, Kg (lb)	kg (lb)	61 (134)
---------------------------------	---------	----------

MATERIAL

Material - Insulators		PTFE
Material - Reflecting Screen		Galvanised steel

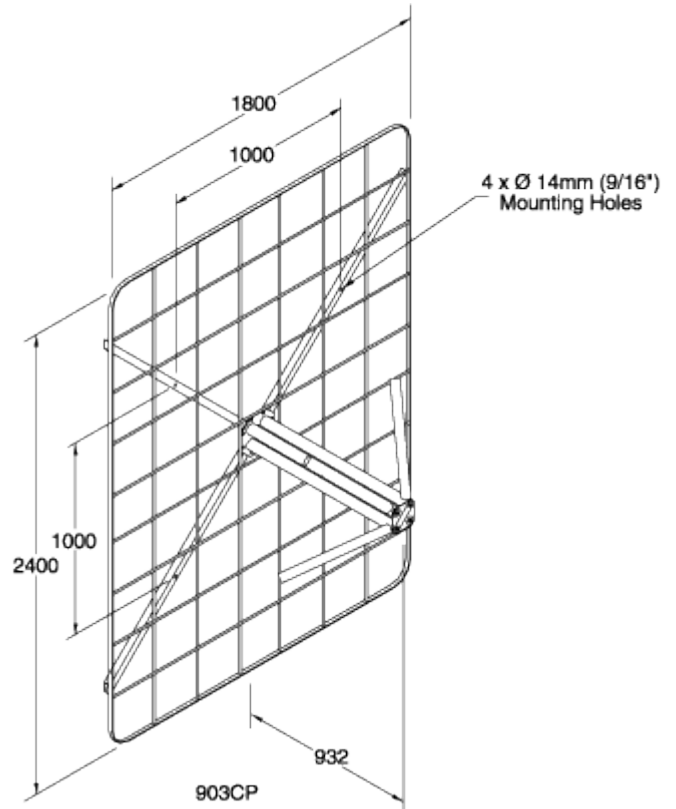
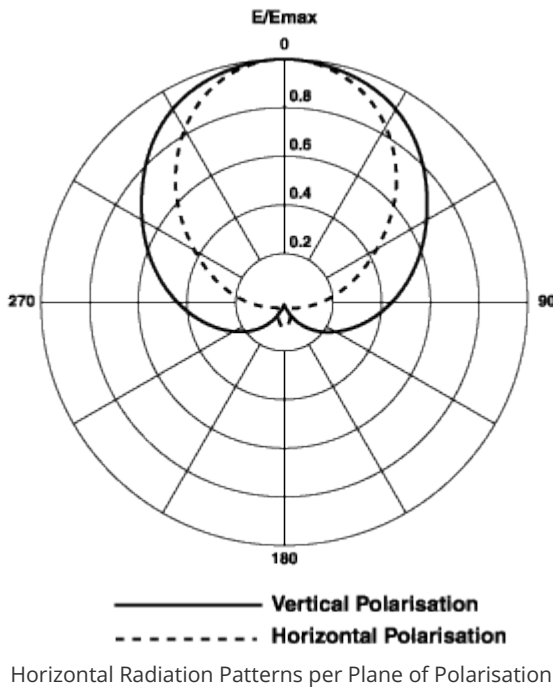

[External Document Links](#)

Notes

Note 1 Power rating per input is limited by input connector. 4kW for 7-16 DIN, 5kW for 7/8" EIA